

THREADED BALL CHECK VALVE PN10



Certificate 3.1

Size : DN 1" to 3"
Ends : Threaded female BSP
Min Temperature : - 10°C
Max Temperature : + 80°C
Max Pressure : 10 Bars
Specifications : Ball type
Vertical or horizontal installation
Removable bonnet

Materials : Ductile iron EN GJS-400-15

THREADED BALL CHECK VALVE PN10

SPECIFICATIONS :

- Ball type
- Vertical with ascendant fluid or horizontal (respect the flow direction indicated by the arrow)
- Female / female BSP threaded
- Easy maintenance thanks to the bolted bonnet
- Anti-corrosion epoxy painting RAL 5005 blue color, 250 microns thickness
- Anti-corrosion stainless steel bolting

USE :

- Water distribution and watering
- Min Temperature Ts : - 10°C
- Max Temperature Ts : + 80°C
- Max Pressure Ps : 10 bars

HEAD LOSS GRAPH :

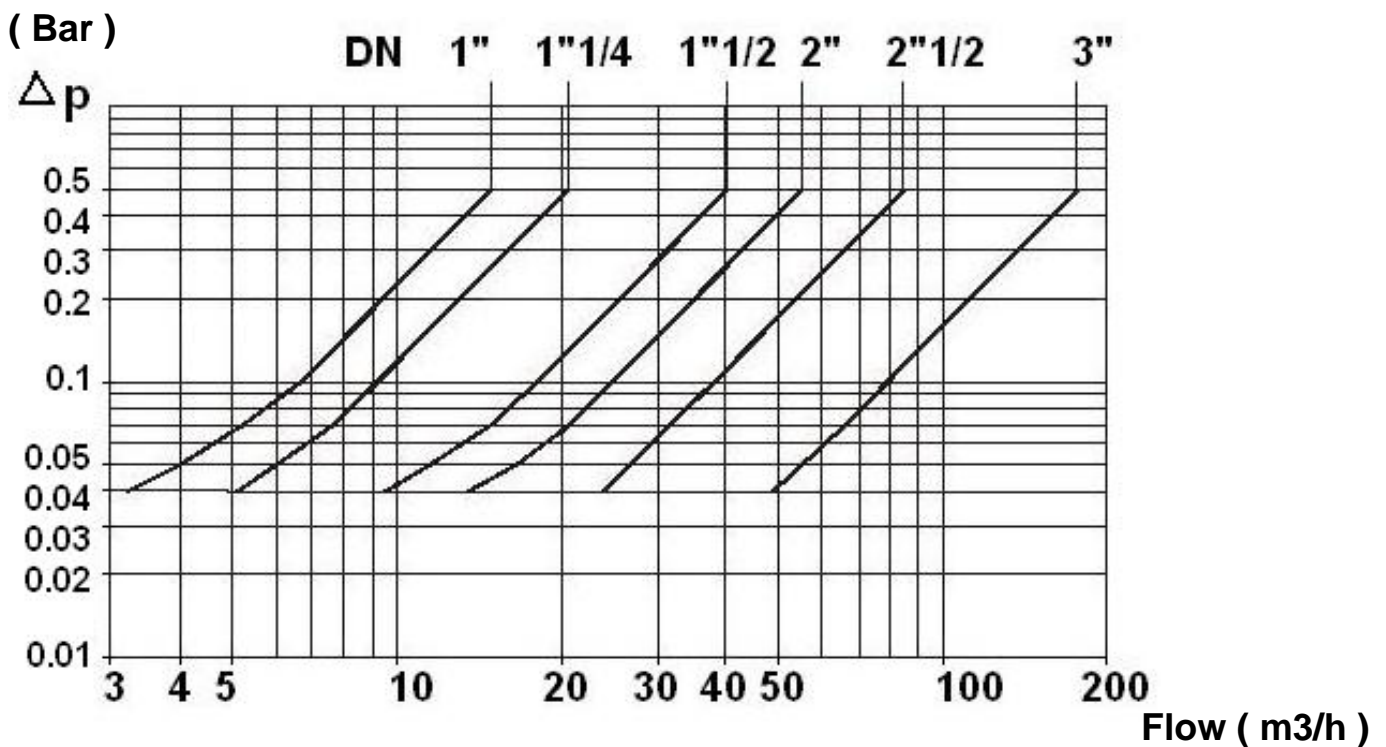

FLOW COEFFICIENT Kvs (in m3/h) :

DN	1"	1"1/4	1"1/2	2"	2"1/2	3"
Kvs (m3/h)	21	29	57	78	120	250

THREADED BALL CHECK VALVE PN10

RANGE :

- Female / female threaded cylindrical BSP Ref. 331 from DN1" to 3"

MATERIALS :

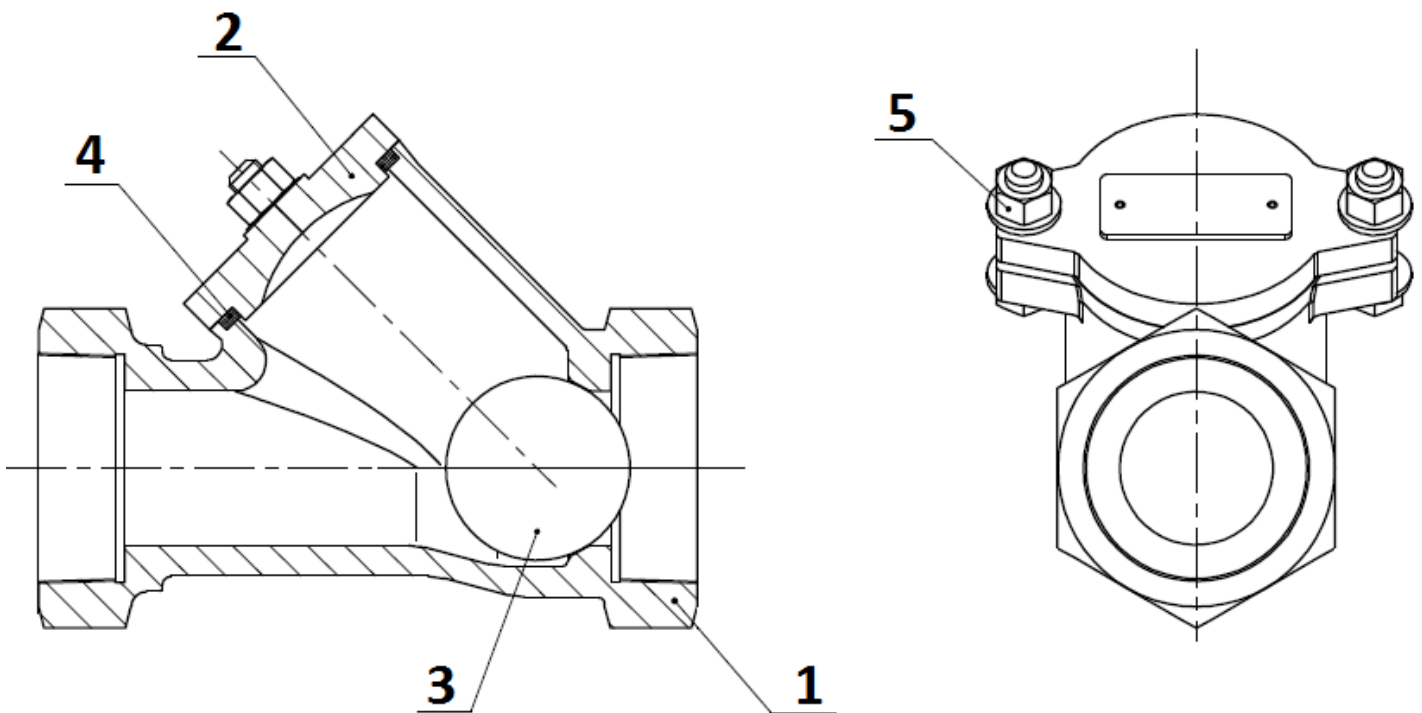

Item	Designation	Materials
1	Body	Ductile iron EN-GJS-400-15
2	Bonnet	Ductile iron EN-GJS-400-15
3	Ball DN 1" – 1"1/2	NBR
3	Ball DN 2" – 3"	Aluminium coated NBR
4	Bonnet gasket	NBR
5	Bolting	AISI 304

THREADED BALL CHECK VALVE PN10

SIZE (in mm) :

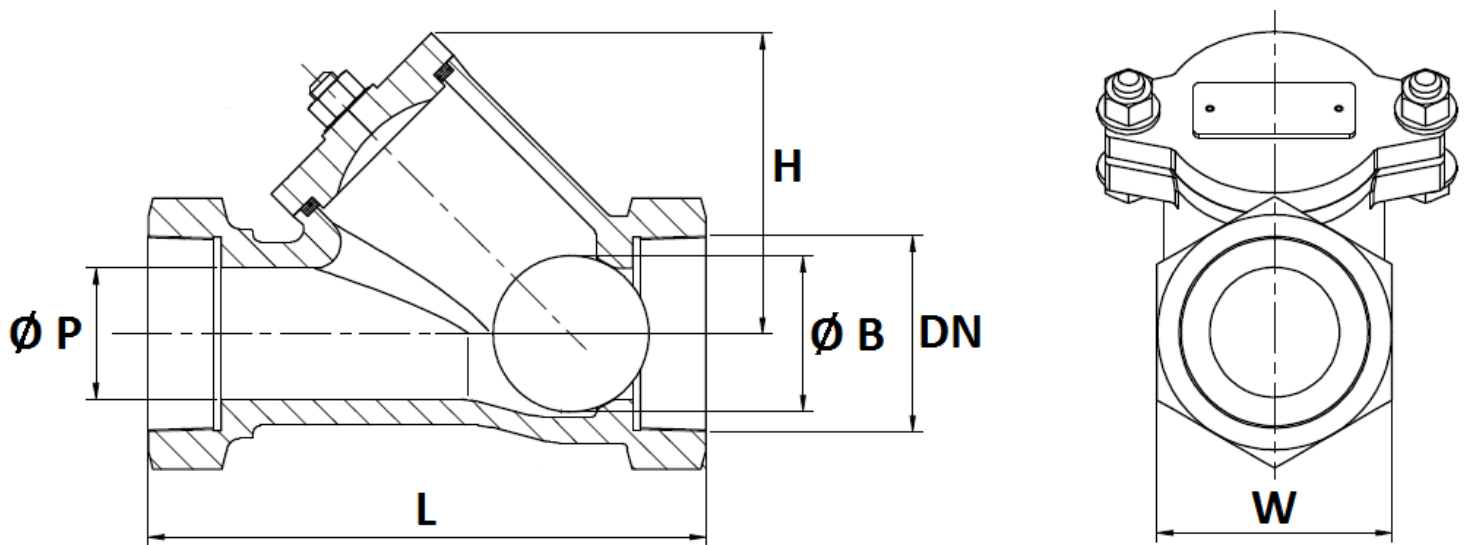

Ref.	DN	1"	1"1/4	1"1/2	2"	2"1/2	3"
331	L	141	141	150	175	214	248
	H	73	76	91.5	111	115	160.5
	$\varnothing B$	40	40	50	60	60	95
	$\varnothing P$	24	30	37	51	50	80
	W (on flat)	40	50	60	70	90	108
	Weight (in Kg)	1.51	1.85	2.76	4.59	5.98	11.57

THREADED BALL CHECK VALVE PN10

STANDARDS :

- Fabrication according to ISO 9001 :2008
- DIRECTIVE 2014/68/EU : Products excluded from directive (Article 1, § 2b)
- Certificate 3.1 on request
- Threaded BSP cylindrical female according to ISO 228-1
- **Body** test according to ISO 5208, Rate A

INSTALLATION POSITIONS :

Vertical position (Ascendant fluid)

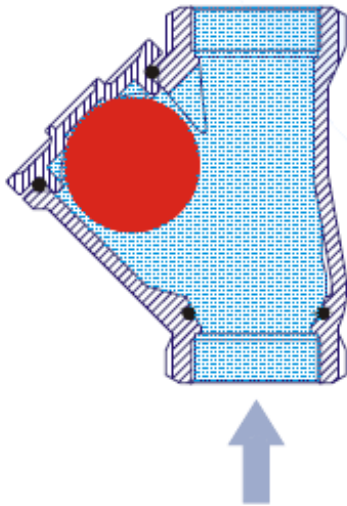

Horizontal position

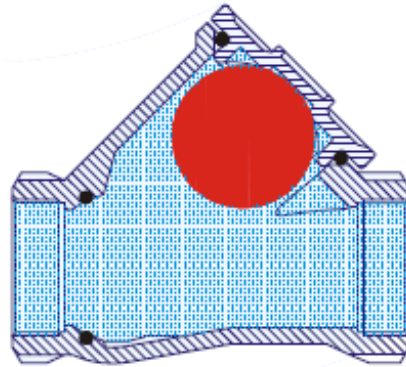



THREADED BALL CHECK VALVE PN10

INSTALLATION INSTRUCTIONS

GENERAL GUIDELINES :

- Ensure that the check valves to be used are appropriate for the conditions of the installation (type of fluid, pressure and temperature).
- Be sure to have enough valves to be able to isolate the sections of piping as well as the appropriate equipment for maintenance and repair.
- Ensure that the valves to be installed are of correct strength to be able to support the capacity of their usage.

INSTALLATION INSTRUCTIONS :

- **Before installing the check valves, clean and remove any objects from the pipes** (in particular bits of sealing and metal) which could obstruct and block the valves.
- **Ensure that both connecting pipes either side of the check valve (upstream and downstream) are aligned (if they're not, the valves may not work correctly).**
- **Make sure that the two sections of the pipe (upstream and downstream) match, the check valve unit will not absorb any gaps. Any distortions in the pipes may affect the tightness of the connection, the working of the check valve and can even cause a rupture.** To be sure, place the kit in position to ensure the assembling will work.
- Before starting the fitting, ensure that the threads and tapping are clean.
- **If sections of piping do not have their final support in place, they should be temporarily fixed. This is to avoid unnecessary strain on the check valve.**
- The theoretical lengths given by ISO/R7 for the tapping are typically longer than required, the length of the thread should be limited, and **check that the end of the tube does not press right up to the head of the thread.**
- When screwing the check valve, ensure that you only rotate on screwed side by the 6 ended side. Use an open ended spanner or an adjustable spanner and not a monkey wrench.
- **Never use a vice to tighten the fixings of the check valve.**
- Do not over tighten the check valve. Do not block with any extensions as it may cause a rupture or weakening of the casing.
- If there is a direction changing or if there's another material, it's better to take away the check valve so that it is outside the turbulence area (**between 3 and 5 times the ND before and after**).
- After a pump please refer to **FD CEN/TR 13932** to install the check valve :
 - If it is essential to keep priming the pump, a non-return check valve can be fitted to the suction pipe at a distance **L1 (straight length suction) > 10xD1 (diameter suction)**
The check valve is designed to meet the maximum flow rate in service
 - In other cases, the non-return check valve is mounted on the discharge pipe at a distance of